

LP Series Hydraulic Torque Wrenches



- Certified Torque Accuracy + / -3%
- Calibration Certification supplied with each tool



- Powerful
- Compact
- Accurate
- Durable



- Faster
- Light-Weight
- Efficient

Extreme Low Profile, Engineered to fit the tightest applications!

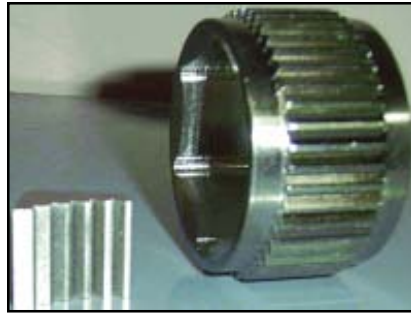

- **Unique Ratchet Tooth Design** - for superior durability and accuracy.
- **TITAN Tru-Swivel™** - Advanced patented, Multi-Axis design provides a low profile combined with ease of motion.
- **Finely Crafted** - of the highest quality Aircraft Grade Materials for unrivaled strength and long life.
- **Ratcheting Assurance Mechanism** - for hands free safety and unmatched repeatability.
- **Patented Energy Disbursement System** - eliminates piston and cylinder damage due to over-stroke.
- **Sleek Design** - affords Easy Fit on the tightest bolt patterns.
- **Unique** - "Wide Track" Ratchet Pawl Mechanism distributes stress better than other designs for longer tool life and reduced repair costs.
- **Comparable width link and cylinder** - due to oval piston design
- **Aluminum-bronze drive bushings** - to reduce friction.
- **Tight Radius Link cassettes** - engineered from FEA.
- **"Set Back" Cylinder Design** gives the accessibility of non-holding pawl tools with the advantages of a holding pawl.

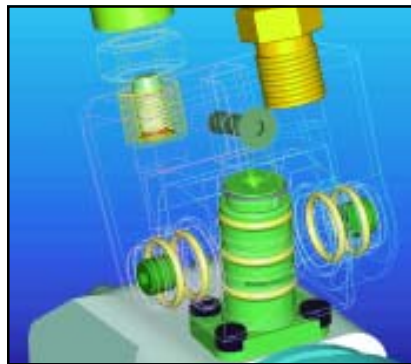

Accessories for the LP Tool

- ALCO extended reaction arm
- Reaction arms
- Hex & 12 pt. step-down sleeves
- Stack sockets
- Square drive adapter
- Hex stock



"The New Standard for Hydraulic Torque Wrenches"

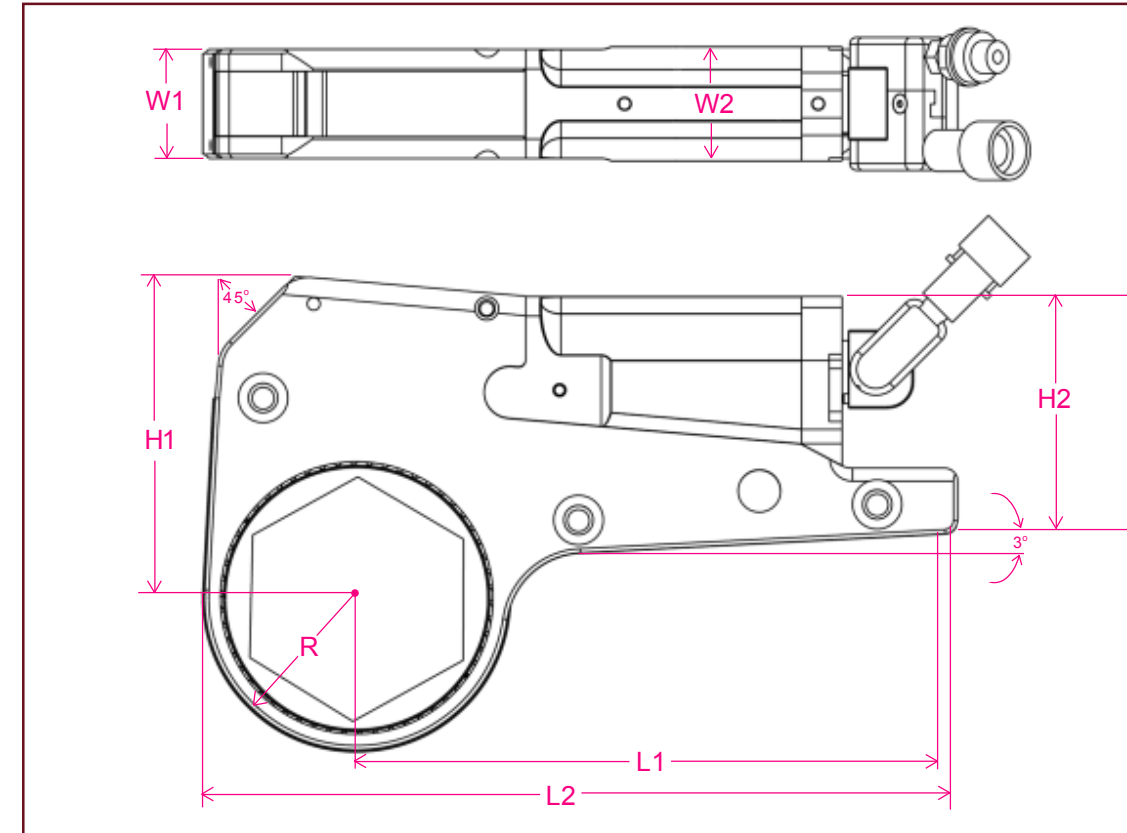

TITAN MODEL NUMBER	Units	LP-2	LP-4	LP-8	LP-16	LP-32
Range of Hex Sizes A/F	(in) (mm)	3/4 to 2-3/8 19 to 60	7/8 to 3-1/8 22 to 80	1-1/4 to 4-1/2 32 to 115	1-5/8 to 5 41 to 127	2-3/16 to 6-1/8 56 to 155
Torque Range	(ft-lb) (n-m)	185 - 1850 250 - 2500	380 - 3800 515 - 5150	800 - 8000 1100 - 11000	1620 - 16200 2200 - 22000	3500 - 35000 4750 - 47500
Cylinder Weight	(lb) (kg)	3.45 1.56	5.8 2.63	10.2 4.62	15.5 7.03	25 11.33
Range of Link Weight	(lb) (kg)	2.20 to 3.50 1.00 to 1.58	5.25 to 7.50 2.38 to 3.40	11.40 to 14.10 5.17 to 6.39	19.70 to 27.60 8.93 to 12.51	27.00 to 39.40 12.24 to 17.87
DIMENSIONS						
L1 -Maximum Reaction Reach	(in) (mm)	7.000 177.80	8.413 213.69	11.312 287.32	14.000 355.60	16.000 406.40
L2 -Overall Length	(in) (mm)	8.900 226.06	10.700 271.78	14.275 362.59	17.950 455.93	19.250 488.95
H1 -Center of Bolt to Top of Tool	(in) (mm)	3.865 98.17	4.775 121.29	6.168 156.67	7.250 184.15	10.500 266.70
H2 -Back End Height	(in) (mm)	3.450 87.63	3.785 96.14	6.050 153.67	8.500 215.9	10.900 276.86
W1 -Tool Width at Link	(in) (mm)	1.250 31.75	1.625 41.28	2.100 53.34	2.350 59.69	2.550 64.77
W2 -Tool Width at Cylinder	(in) (mm)	1.250 31.75	1.750 44.45	2.100 53.34	2.450 62.23	2.800 71.12
R -Tool Radius around Bolt	(in) (mm)	1.030 to 1.751 26.16 to 44.48	1.312 to 2.302 33.32 to 58.47	1.725 to 2.952 43.82 to 74.98	1.95 to 3.5 49.53 to 88.9	2.50 to 4.75 63.5 to 120.65



Low cost step-down sleeves are available in all sizes.



Available in fractional & metric sizes, hex & 12 pt., square & 8 pt.



Patented multi-axis swivel, provides for better accessibility and prevents hose kinking.



Fast, Dependable, Accurate. TITAN LP-Series gets the job done.



Tool lays flat for better accessibilities

All Titan LP Series Tools are manufactured solely from Aircraft Grade, High Strength Alloys selected for their superior stress and fatigue resistant properties.

TITAN Mission Statement

Our mission is to be the leading global provider of high-end bolting solutions for the benefit of our customers, our shareholders, our employees and our partners by providing:

- Direct customer relations and local presence in the markets served.
- Superior products and services.
- Total customer solutions.

Our unwavering mission guides our everyday actions....
Customer driven product development fuels our growth....
Listening to customer needs builds our market leadership....
Continuous improvement is fundamental to our continued success.

Titan Technologies - Different from other companies that sell bolting products and services. Titan is a solutions based company which features a vast array of solutions to any bolting application.



People: Titan enjoys a worldwide network of experienced experts trained to recommend the most cost-effective solution for your bolting job.

Technical Expertise - Bolting applications experience in multiple industries including power generation, oil and gas, chemicals, pulp and paper and more.



Quality: All of our products are designed using the latest aerospace finite element design techniques and machining technology.

Local Service - Extensive network of independent sales representatives and authorized dealers located worldwide.



Engineering: Titan spends a higher percentage of its revenue in research and development to ensure the highest quality and most durable products on the market.

**Quality Guarantee
Extensive Warranty**

ADDITIONAL PRODUCTS & SERVICES OFFERED

- T-Series Hydraulic Torque Wrenches
- HydraJac Bolt Tensioners - Modular Style
- HydraJac Bolt Tensioners - Dedicated Style
- HydraNut Hydraulic Nuts
- Power Spreader Flange Spreaders
- Power Splitter Nut Splitters
- Air Tite Pneumatic Torque Wrenches
- Sockets & Accessories
- Striking Wrenches
- Rentals For All Product Lines
- Equipment Service & Repair
- Calibration Service



9001 Jameel Street Suite 180
Houston, TX 77040

Toll-Free: 866.345.8484

Phone: 281.449.9994 • Fax: 281.449.9996

Email: sales@titanti.com

http://www.titanti.com

Your Local **TITAN** Representative:



Dependable • Fast • Efficient
**TITAN LP Series
Hydraulic Torque Wrenches**
are an integral element to get
your bolting job done right, on time, every timeSM

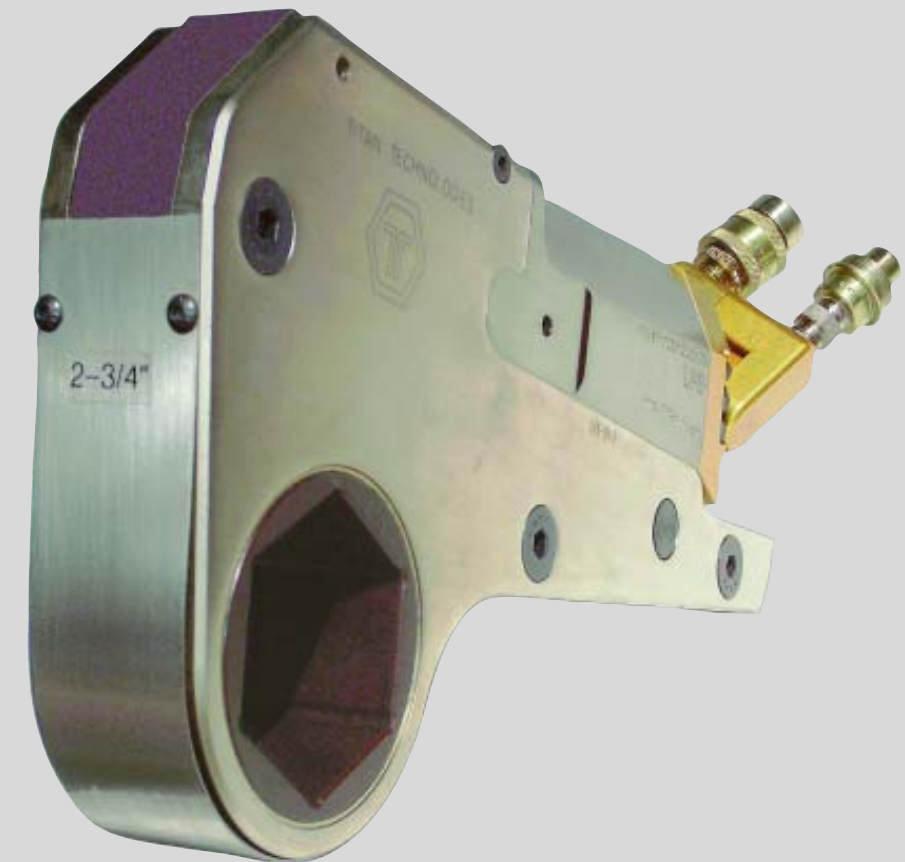

TITAN is a leading bolting solutions provider committed to offering the most reliable and comprehensive bolting solutions world wide.

