

USE AND INSTALLATION OF ALL *AiRTX* STAINLESS STEEL CONTROL COOLERS Models 70008x, 70015x, 70025x, 70035x



1. COMPRESSED AIR SUPPLY

Air supplies are plagued with condensed water vapor and droplets in the air lines. This condensation leads to rust and dirt in the airlines. Also, some compressors will allow oil or oil vapor to enter the air lines.

Small orifices in the *AiRTX* Stainless Steel Control Cooler, may become clogged with rust, dirt, and water droplets.

A 5-micron filter will separate 99% of the foreign material from the air supply, allowing virtually maintenance free operation. The use of an oil filter with an effective filtration of 0.01 ppm will remove the oil droplets for an even cleaner air supply.

Model 90175 automatic drain air filter can be used with all Stainless Steel Coolers to remove foreign material and water droplets. This filter is standard with the thermostatic Control Cooler models.

Model 91175 oil filter can be used with all models.

Keep in mind that the current line or air hose might contain dirt or oil and should be blown out before installation. Also, pipe thread sealant or tape must be carefully applied to avoid clogging product orifices.

2. COMPRESSED AIR SUPPLY LINE SIZE

To obtain maximum performance from the *AiRTX* products, adequate amounts of air pressure and volume must be present. Line pressure of 70-90 psi can be available without a sufficient volume (cfm) of air. To ensure that both pressure and volume are available to efficiently operate the *AiRTX* Stainless Steel Coolers, a line size of 1/4" pipe or 1/2" hose should be used for applications up to 10 ft. from the compressed air main header. Use 3/8" pipe or 3/4" hose up to 20 ft. and 1/2" pipe or 1" hose up to 50 ft. from the header.

3. USE AND INSTALLATION OF STAINLESS STEEL CONTROL COOLER

The last 2-digits of the Stainless Steel Control Cooler models, indicate the cfm usage at 80 psi. The generators determine the volume of air through the Control Cooler. These generators are rated 8, 15, 25, and 35 cfm at 80 psi. To ensure that your air compressor can generate these volumes, the (horse power) of the compressor can be multiplied by four to determine the cfm capacity. A multiplier of 5 can be used on newer compressors over 30 horsepower.

The Model Control Cooler 70025x is equipped with a 25 cfm generator and 8' of vinyl ducting to route the cold air inside the cabinet. This will provide 1500 BTU of cooling. This is sufficient to cool a cabinet that is 6 ft. x 6 ft. x 2 ft. from a 140°F maximum inside temperature to 90°F., provided 80 psi air is available going into the *AiRTX* Control Cooler.

When 80 psi is not available, the potential BTUs of cooling must be reduced by 25% at 60 psi, or 50% at 40 psi. The Model 70008x will cool cabinets of 4' x 3' x 1' or smaller.

The thermostat Models 70308, 70315, 70325, 70335 are very useful at controlling compressed air usage as it only operates when internal cabinet temperature exceeds 90°F. Each thermostatic model includes the Stainless Steel Control Cooler and following components:

<u>Part number</u>	<u>Description</u>
70000-14	8' vinyl ducting with muffler
90300	thermostat preset 90°F (32°C)
90175	1/4" 5 micron auto drain filter
90301	1/4" normally closed 2-way solenoid
90303	.002 MFD Capacitor

4. OPERATION OF COOLING

The *AiRTX* Stainless Steel Control Cooler is factory set to deliver the maximum cooling needed to maintain a desired temperature inside your control panel.

At 80 psi, 17.5 cfm (70% of 25 cfm) of cold air will exit from the Model 70025x Control Cooler into the panel, providing 1500 BTU of cooling.

At 80 psi, Model 70015x will deliver 10.5 cfm of cold air inside the cooler, providing 900 BTU's of cooling. Model 70035x delivers 2500 BTU's of cooling based on 70% of 35 cfm or 24.5 cfm of cold air.

The bladder valve, located at the base of Control Cooler, will automatically release hot air from the cabinet, maintaining a positive pressure inside the cabinet of 10" water column. The automatic release of air through the bladder valve enables you to close off open conduit entrances, louvers and air leaks. A sealed cabinet is also more efficient, as the cold air enters only the cabinet and doesn't escape to the atmosphere, generating increased compressed air usage. A sealed cabinet also eliminates potential condensation from forming on the components. The bladder valve keeps the integrity of a Nema 4, 4x, or 12 cabinet. The Stainless Steel construction allows for wash-down situations. "UL Listing is for use on a flat surface of a type 4, 4x, 12 enclosure".

5. DUCTING

The 8ft. of vinyl ducting connects to the cold end of the Control Cooler inside the electrical cabinet. The ducting allows more efficient use of the cold air by routing the cold air to the hottest spot. By cutting a hole in the tube at the hot spot, the cold air cools more effectively, restricting the high temperature increase of the particular hot control.

The muffler end of the ducting should be placed toward the bottom of the cabinet. As the cold air exits from the muffler, it rises as it heats and provides more even cooling throughout the cabinet.

6. CLEANING AND MAINTENANCE

The *AiRTX* Control Cooler has no moving parts. Clean, compressed air moving through the tube will not cause wear on the parts and will provide you with the same reliable service for an indefinite period of time.

Occasionally, dirt, water, or oil may enter the tube from the compressed air supply and hinder the performance. If this happens, simply take the unit apart, clean the parts, and reassemble, tightly replacing the cold end cap to properly seat the generator.

7. INSTALLATION AND MOUNTING FOR ALL CONTROL COOLER MODELS

The drawing suggests a way the Control Cooler can be mounted regardless of which Model you ordered. The Stainless Steel Control Cooler operates the same in any plane, so it can be mounted perpendicular to the side or back of the cabinet. It can also be mounted using a 90° electrical elbow. The drawing shows the thermostat, solenoid, and automatic drain air filter if you ordered one of the thermostatic Models. The Control Cooler requires a standard 3/4" electrical knockout for installation and a 1/2" electrical knockout for the thermostat.

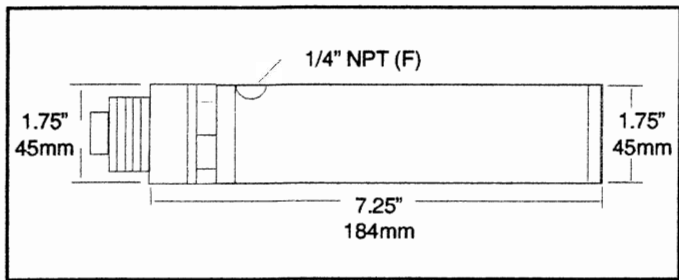

Models 70015x, 70025x, 70035x

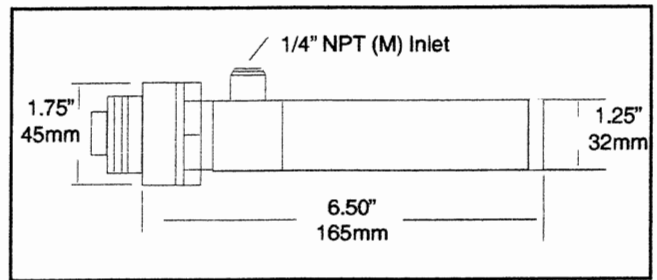

Model 70008x

CHANGING FACTORY TEMPERATURE SETTING OF THERMOSTAT FROM 90°F. REQUIRES ADJUSTABLE THERMOSTAT MODEL 90300-1.

This unit is calibrated for 90°F. To increase setting turn screw CCW. The arrow on the head of the controller indicates the direction to turn adjusting screw to increase the temperature setting. Disassembly of the adjusting screw may render the thermostat inoperative. **If you must adjust the factory temperature setting be very careful.** The range of the thermostat is very large and even a 1/16 turn of the thermostat screw will vary the temperature by 10°F. The adjusting rate is approximately 90°F per complete revolution. Observe electric rating marked on unit. Damage resulting from mishandling, improper application or injurious ambient cannot be covered by this warranty.

Capacitor note: The capacitor is a very sensitive slow make-and-break thermostat switch. Under certain conditions such as small loads or excessive vibration, addition of the capacitor will result in optimum unit performance, and relieve chattering. The typical recommended capacitor is a .01 microfarad capacitor rated at a minimum 600 VDC for 120 VAC circuits and a minimum 1000 VDC for 240 VAC circuits.

THE TEMPERATURE SETTING OF THE THERMOSTAT FROM THE FACTORY IS 90°F.

THIS IS DONE FOR 2 MAIN REASONS:

1. If the setting of the inside of the control cabinet is 70°F for example, then on a hot 90°F day, sweating could occur on the outside of the cabinet.
2. The critical temperature for electronic controls is 100 to 104°F. 20% of the life of the controls is lost at temperatures higher than 104°F.

A factory setting of 90°F allows for a safe operating temperature, prevents excessive condensation, and conserves air usage.

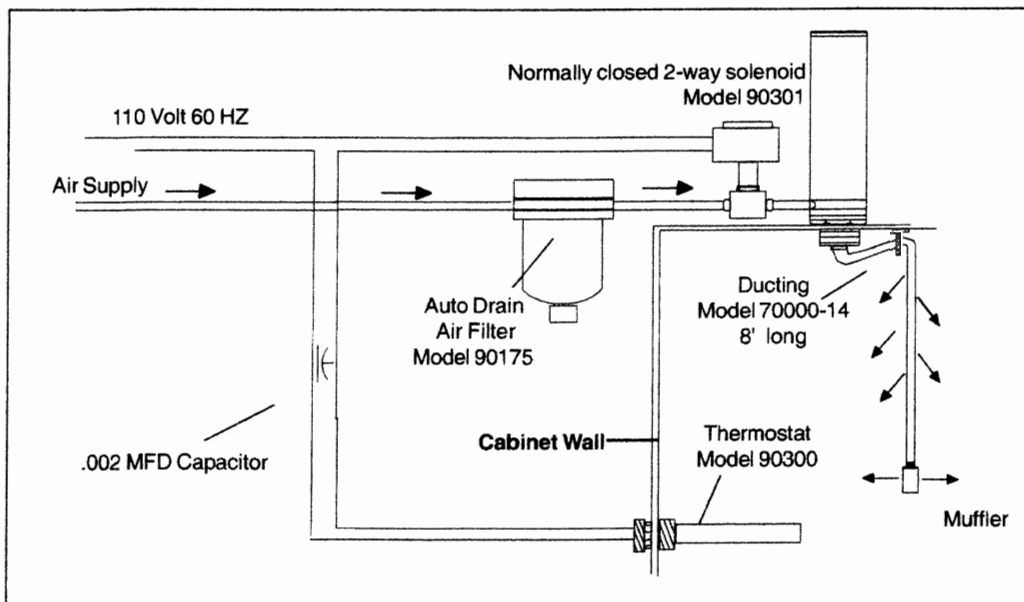

Installation of Thermostatic Control Models 70308x, 70315x, 70325x, 70335x

8. CONTINUOUS RUNNING OPERATION; MODELS 70008x, 70015x, 70025x, 70035x

For Control Coolers operating continuously, those without thermostats, condensation may form on the outside of the Cabinet. If this occurs, regulate the compressed air to a lower setting (50-60 psi) This will drop the inlet compressed air temperature to 30°F instead of 50°F at 80 psi and reduce the water droplets on the outside of the cabinet while still maintaining proper inside cooling. The 8' of vinyl ducting and internal muffler should always be installed to properly distribute cooling to all internal components.